



- Document Destruction

- Paper Shredding

- Plastic Shredding

ITs
GREEN

EV45E

ITs
GREEN

PERFORMANCE CHARACTERIS- TICS:

- 22 Kw/ 30 Hp Maximum Power
- 28—30 Rpm Cutter Speed Rotation
- 4, 8, 12 or 16 mm Shred Width
- 450 mm x 375 mm Cutting Chamber Opening
- 18,9 m/min Cutting Speed
- 1500 Kg per hour*
- 72 Dba @ 1 meter (no load)
- Recommended In-feed: Bin Tipper or Conveyor Belt
- Recommended Out-feed: Storage Bin or Conveyor Belt
- Electronic Controls



* Normal Office Paper Under Ideal Conditions

Specifications are subject to change without notice. Contact your nearest distributor/ agent for up-to-date specifications prior to purchase.

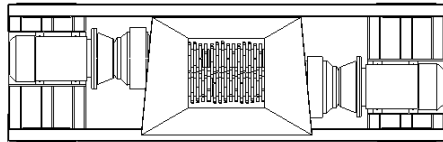
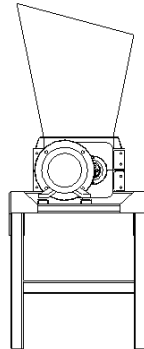
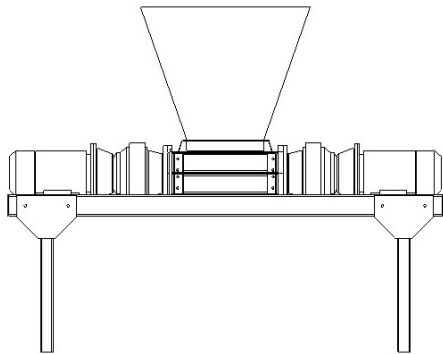

PHYSICAL DIMENSIONS:

Total Height:	2180 mm
Total Length:	2570 mm
Total Width:	830 mm
Ground Clearance (underneath shredder):	810 mm
Ground to Hopper Entrance Lip Height:	1815 mm
Hopper Opening:	930 x 800 mm
Shredder Chamber Opening:	450 x 375 mm

SHREDDER NAME:	EV45E (Electric)
Number of Motors	2 x 11Kw
Number of Gearboxes	2
Type of Gearboxes	Planetary Reduction
Cutter Width	4mm, 8mm, 12mm or 16mm
No. of Hooks per cutter	3
Cutter Diameter	200mm
Distance between Shafts	165mm
Hex Shaft Diameter	77mm AF
Critical Shaft Length	450mm
Cutter Chamber Opening	450mm x 375mm
Cutting Chamber Height	250mm
Hopper Height	1000mm
Stand Height	930mm
Total Height	2180mm
Floor Footprint Dimensions	830mm x 2570mm
Weight	1200 Kg
Capacity/ Throughput Rate	1500 kg per hour*
Cutting Tip Force	16000 Kg/ 35200 lbs per meter of shaft length

* Normal Office Paper Under Ideal Conditions

Specifications are subject to change without notice. Contact your nearest distributor/ agent for up-to-date specifications prior to purchase.